

TAKING CARE
OF DEMANDING
ACOUSTICS

ECOPHON MASTER™



Contents

04 ABOUT ECOPHON

06 GOOD ACOUSTICS MATTER EVERYWHERE

08 BUILDING ON BETTER

10 TAKING CARE OF DEMANDING ACOUSTICS WITH ECOPHON MASTER™

12 ECOPHON MASTER PRODUCT RANGE

- 14 Master A
- 14 Master B
- 15 Master Ds
- 15 Master E
- 16 Master Eg
- 16 Master F
- 17 Master SQ
- 17 Master Rigid A
- 18 Master Rigid E
- 19 Master Rigid Dp

20 COLOURS AND SURFACES

22 ECOPHON MASTER OVERVIEW

24 SYSTEM PROPERTIES

Acoustics, technical properties and installation diagrams

This publication shows products from Ecophon product range and those of other suppliers. The specifications are intended to provide a general guide to which products are most suitable for the preferences indicated. Technical data is based on results obtained under typical testing conditions or long experience in normal conditions. The specified functions and properties for products and systems are only valid on condition that instructions, installation diagrams, installation guides, maintenance instructions and other stated conditions and recommendations have been taken into consideration and followed. Deviation from this, such as changing specific components or products, will mean that Ecophon cannot be held responsible for the function, consequences and properties of the products. All descriptions, illustrations and dimensions contained in this brochure represent general information and shall not form part of any contract. Ecophon reserves the right to change products without prior notice. We disclaim any liability for misprints. For the latest information go to www.ecophon.com or contact your nearest Ecophon representative.



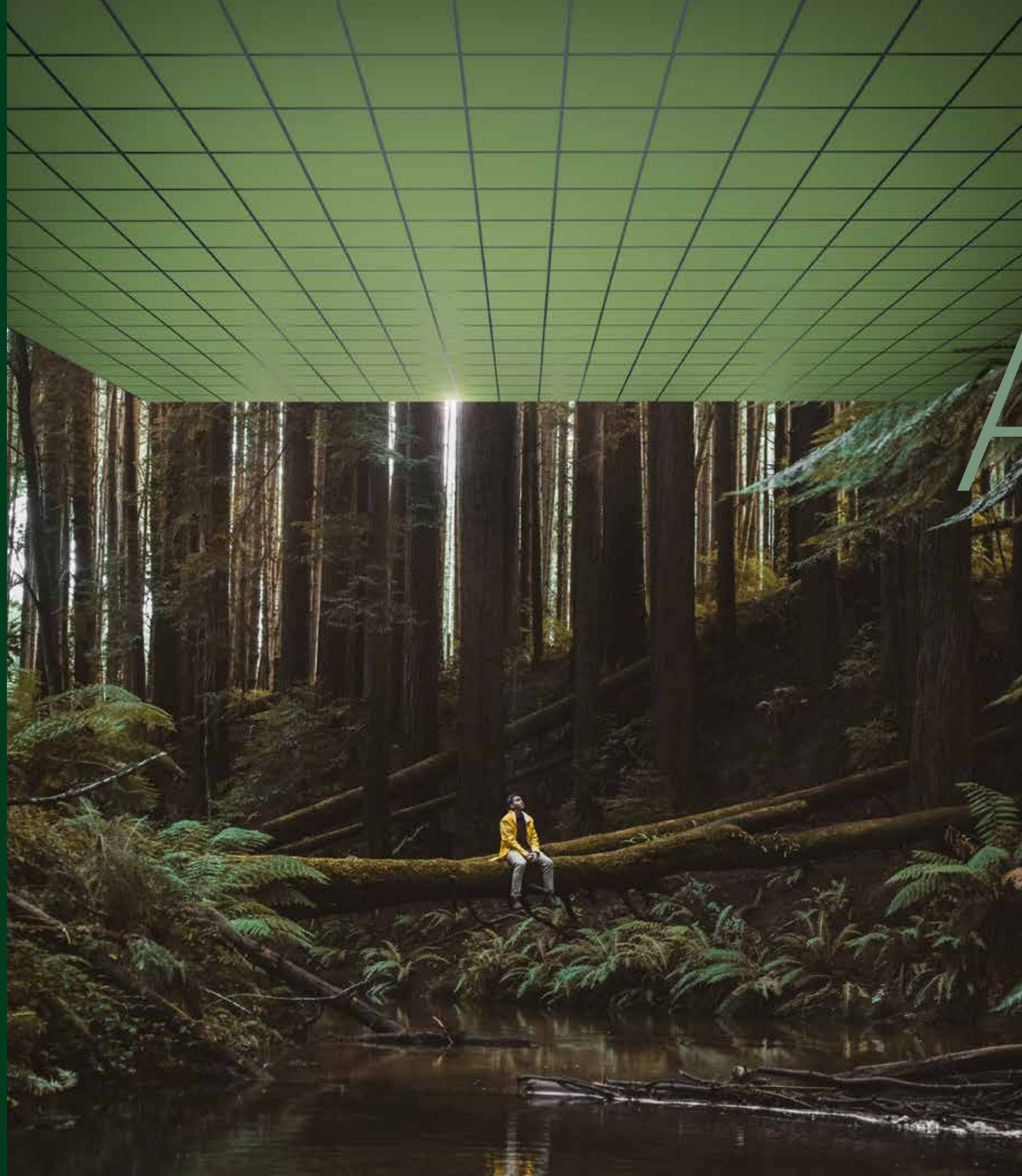

A sound effect

ON PEOPLE

Saint-Gobain Ecophon contributes to good indoor environments for working, healing and learning. We do this by developing, manufacturing and delivering acoustic products and systems designed around the natural evolution of human hearing – replicating the outdoor sound experience indoors, because that's just better for people.

Having a sound effect on people, in every way we can, is what we do proudly. That promise makes every one of us a passionate advocate for the importance of room acoustics to people's wellbeing – whatever the space, activity or need.

Good acoustics

MATTER EVERYWHERE

The importance of acoustics is underappreciated. Sound impacts us in daily life, and the scientific support for improving our indoor sound environments is well-documented.

And what exactly is an ideal indoor sound environment for people? One based on how we experience sound outside. The human auditory sense is naturally adapted to an outdoor environment where there is not any sound reflections from ceilings and walls.

That's why most of what we do at Ecophon is about replicating the acoustic qualities found in nature for indoor environments. We want to optimise indoor spaces to our natural way of hearing, so that speech and sound is easy to hear and understand, when needed, improving performance and wellbeing.

Usually that starts with the ceiling. A wall-to-wall acoustic ceiling is the easiest way to get a large sound-absorbing surface area into a space, and is usually the best way to reduce sound strength, shorten reverberation times, and increase speech clarity and overall hearing comfort.

But for a truly optimal sound environment, you'll also likely need different kinds of sound absorbers placed strategically throughout the space—wall-mounted panels and free-standing dividers are just two examples. In other words, a holistic approach is the best way to reduce the overall sound level and sound propagation in a room. Ecophon is here to help.

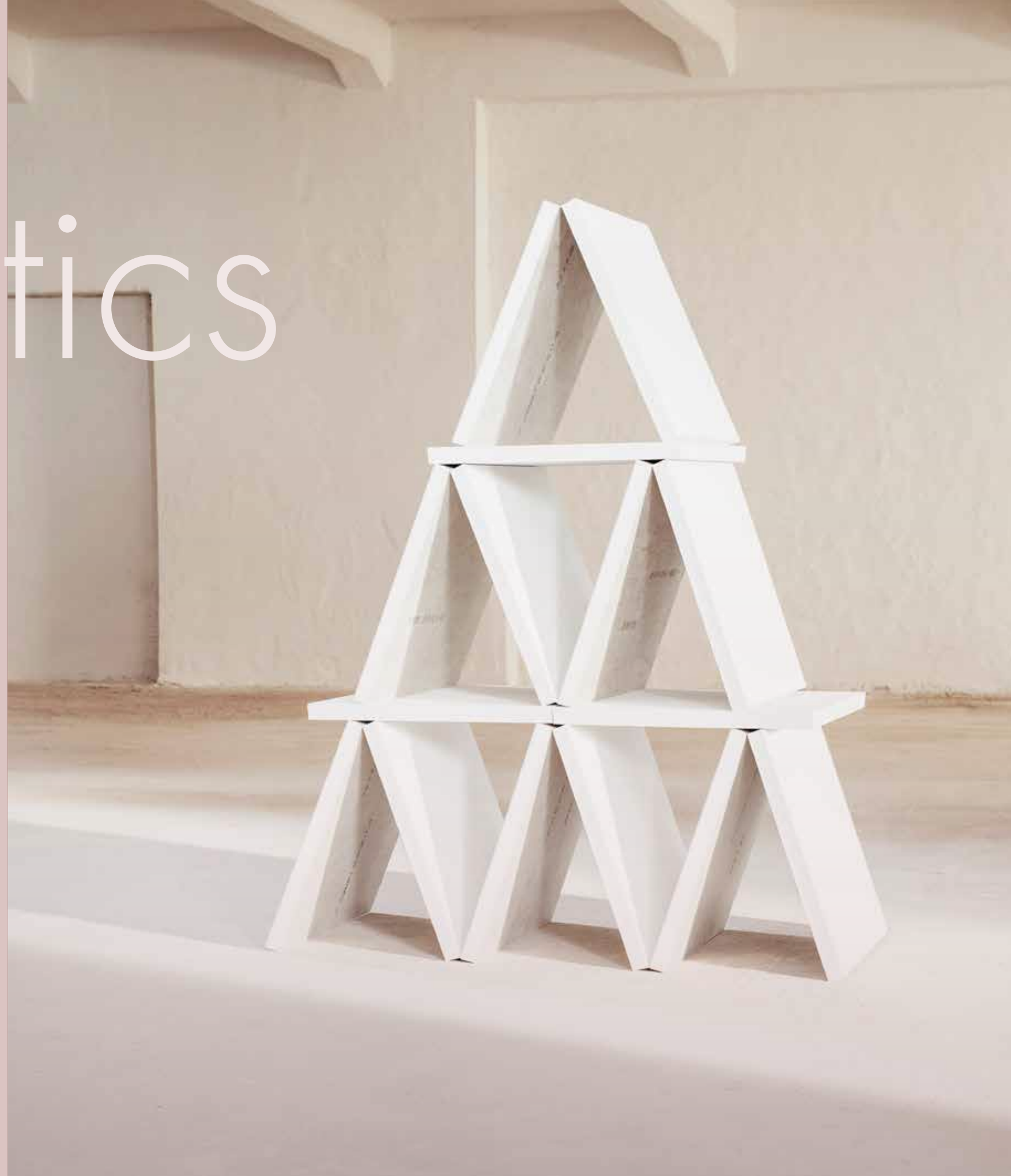



Building on

BETTER

Sustainability is more than a word – it’s a collective movement to protect people and the planet that requires honest commitment and genuine care. That’s why Ecophon is building on better materials, transparency, and principles, to name just a few.

We actively support an industry-wide drive to standardized, easy-access Environmental Product Declarations for individual products, rather than product families. Their inclusion of full lifecycle data, from raw material sourcing to end of life, rather than only the favorable stages. A move away from self-declared labels, or non-independently verified sustainability claims. And for any promises of net zero carbon emission targets to be validated by the Science-Based Targets initiative.

If we’re going to build a sustainable future, it has to start with an honest approach, high ambition and the best of intentions – to build on better together.



Ecophon Master™

TAKING CARE OF DEMANDING ACOUSTICS

Ecophon Master™ is at the forefront of acoustic innovation and unrivalled in meeting acoustically challenging environments. The result provides excellent sound absorption and speech intelligibility.

- Absorption class A
- Offers 2 different product systems with 7 different edges
- Premium surface with matte look

Spaces where phones are used frequently, or where other high ambient noise levels are to be expected, can be hard to concentrate, be productive or learn in. Master suspended ceiling systems provide exceptional sound absorption and speech clarity - perfect for busy offices, classrooms, or anywhere speech intelligibility is the priority.



Minimum
59%
 post-consumer recycled content

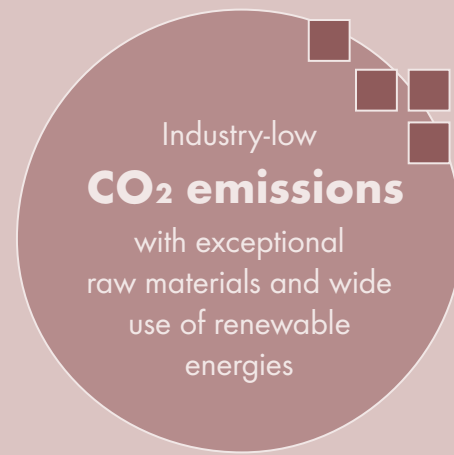

ECOPHON MASTER™ PRODUCT RANGE

Master offer suspended wall-to-wall ceilings with excellent acoustic properties and direct fixing solutions with screws or glue adhesive for a quick and easy acoustic upgrade.

Patent-pending Master Eg is a unique system offering design possibilities with a floating appearance.

Master Rigid systems have a reinforced, durable and impact-resistant surface and is secured in the grid system. Combine with Ecophon Extra Bass for extra low-frequency absorption.

MASTER A

600x600x40
1200x600x40
1200x1200x40



MASTER B

600x600x40
1200x600x40



MASTER Ds

600x600x40



MASTER E

600x600x40
1200x600x40
1200x1200x40



MASTER Eg

600x600
1200x600
1200x1200
2400x600
Patent pending



MASTER SQ

600x600x40
1200x600x40



MASTER RIGID E

600x600x20
1200x600x20
1200x1200x20



SQUARE 43

Edge Eg:
600x600x40



MASTER F

600x600x40
1200x600x40



MASTER RIGID A

600x600x20
1200x600x20
1600x600x20
1800x600x20
2000x600x20
2400x600x20



MASTER RIGID Dp

600x600x20
1200x600x20
Patented system



DOT

Edge Eg:
600x600x40



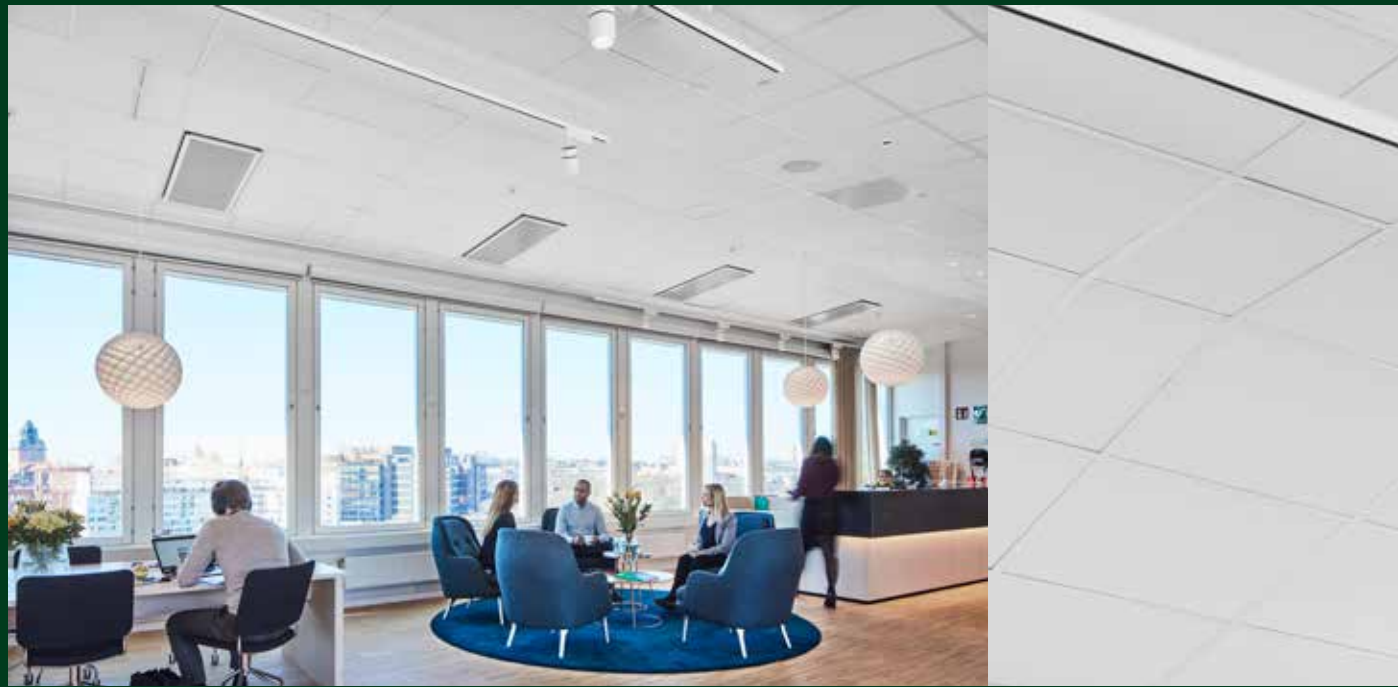

MASTER A
Visible grid system and easy demountable tiles. Available in many formats.

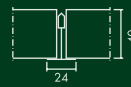

MASTER Ds
Bevelled edges that generates a discreet groove between the tiles. Concealed grid system.

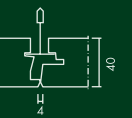

MASTER B
For direct fixing with glue. Ideal for installations that require minimum depth of system.

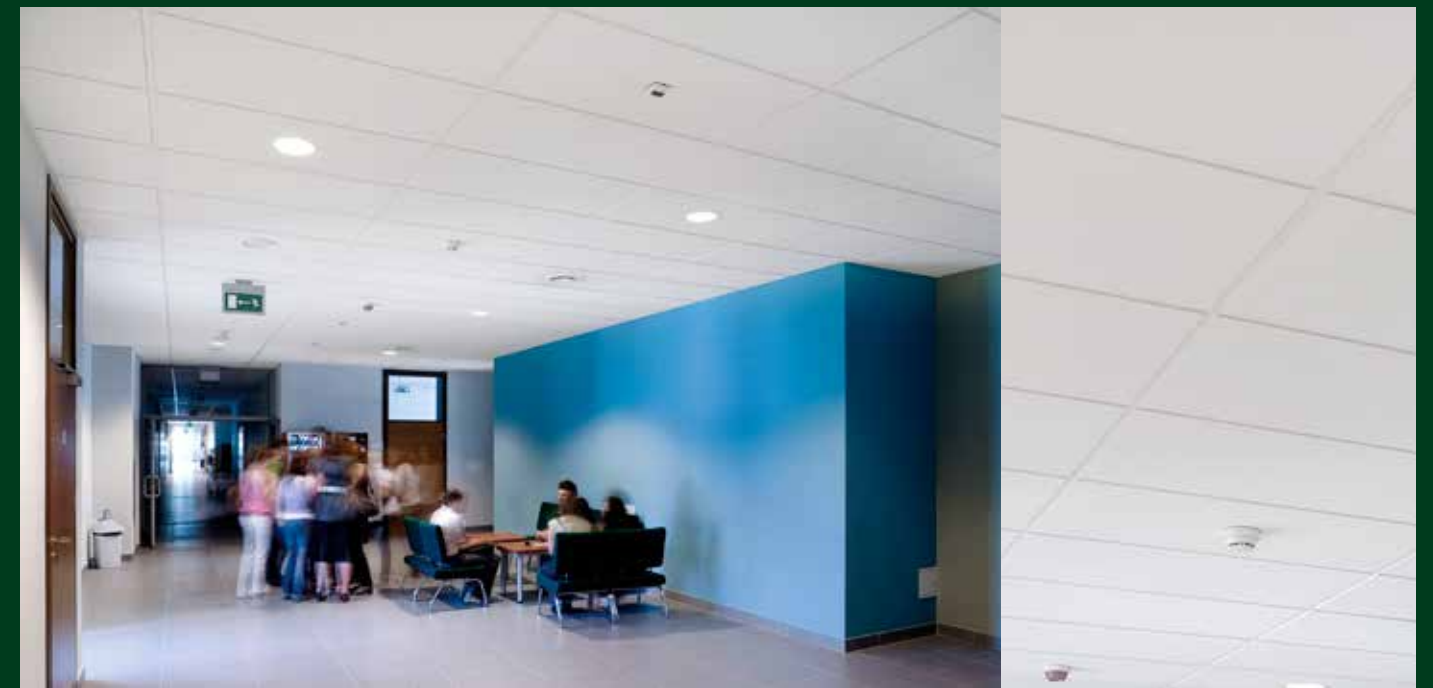
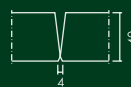

MASTER E
Recessed visible grid system creating a shadow effect on the edge. Easily demountable tiles.

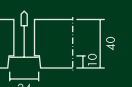



MASTER Eg

Patent pending system with unique edge design painted in two colours with concealed support edges and a floating appearance.



MASTER SQ

For direct fixing with glue. Installed with a gap between each tile.

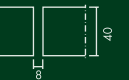

MASTER F

For direct fixing with screws. Ideal for installations that require minimum depth of system.



MASTER RIGID A

Visible grid system with reinforced surface secured by clips but fully demountable tiles. Available in many formats.





MASTER RIGID E

Recessed visible grid system creating a shadow effect on the edge. Reinforced surface secured by clips but fully demountable tiles.



MASTER RIGID Dp

A patented semi-concealed system. Reinforced surface secured by clips but fully demountable tiles.

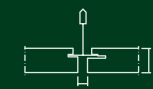

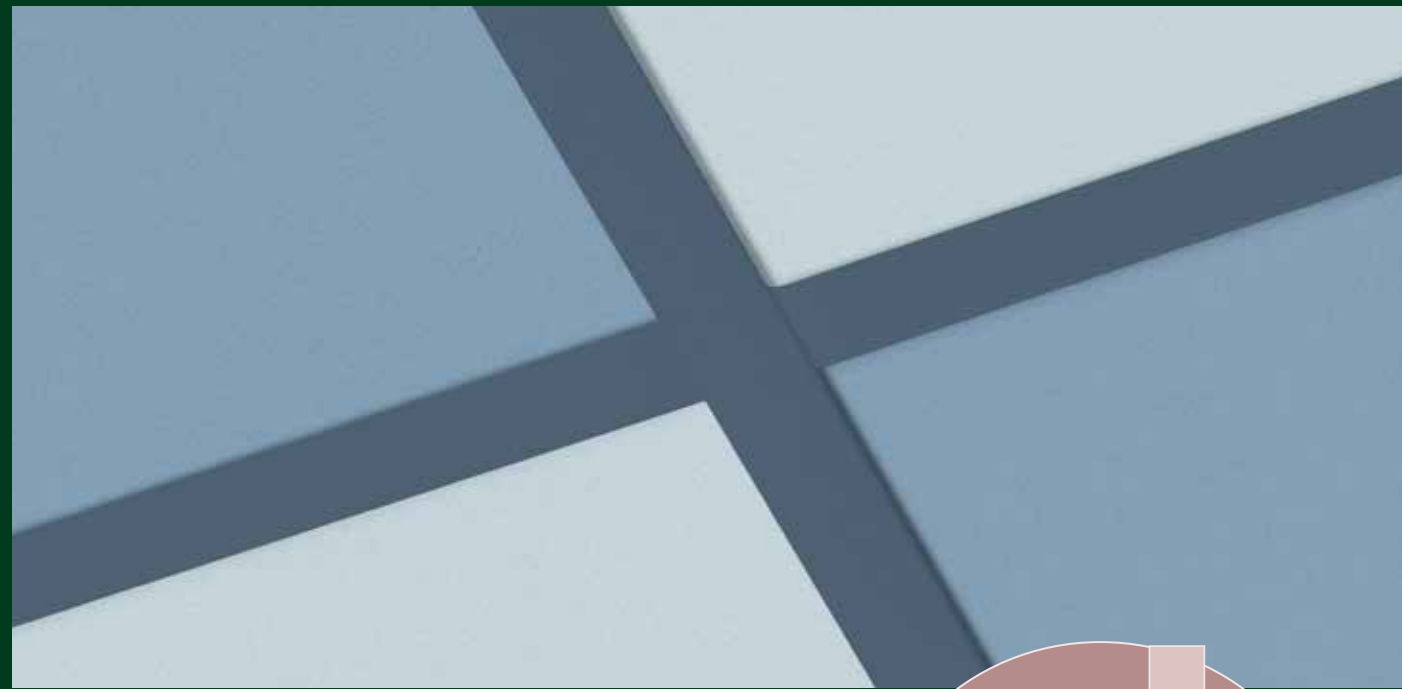

GRID COLOURS

- 15 colour options for grids
- Create your own design
- Closest Akutex FT match creates subtile pattern and mixing FT colours gives more design effect

An acoustic ceiling is often the largest continuous surface in a room. It will affect not only the entire look and feel of the interior, but also the end-users' wellbeing.



COLOURS AND SURFACES

AKUTEX™ FT

The Akutex label guarantees that the product carrying it has a superior surface technology. Our research and development will always focus on visual aspects, acoustic properties, working environment, architectural trends and environmental aspects. This ensures that Akutex is always one step ahead.



WHITE FROST | Light reflectance 85%.
Nearest NCS colour sample S 0500-N.
Grid colour NCS S 1000-N.



OCEAN STORM | Light reflectance 24%.
Nearest NCS colour sample S 4020-R90B.
Grid colour NCS S 4010-R90B.



MORNING DRIZZLE | Light reflectance 69%.
Nearest NCS colour sample S 1002-B.



VOLCANIC ASH | Light reflectance 56%.
Nearest NCS colour sample 2002-Y.



MOONLIGHT SKY | Light reflectance 7%.
Nearest NCS colour sample S 7020-R90B.
Grid colour NCS S 7010-R90B.



CLOUDY DAY | Light reflectance 62%.
Nearest NCS colour sample S 1500-N.



SILVER STONE | Light reflectance 29%.
Nearest NCS colour sample S 4502-Y.



GOLDEN FIELD | Light reflectance 61%.
Nearest NCS colour sample S 1040-G90Y.



PEACH ROSE | Light reflectance 55%.
Nearest NCS colour sample S 1515-Y80R.
Grid colour NCS S 1510-Y80R.



SILK SLATE | Light reflectance 13%.
Nearest NCS colour sample S 7000-N.
Grid colour NCS S 6500-N.



SUNSET HEAT | Light reflectance 20%.
Nearest NCS colour sample S 2070-Y60R.



HIGHLAND FOG | Light reflectance 55%.
Nearest NCS colour sample S 2005-G.
Grid colour NCS S 2005-G20Y.



GOJI BERRY | Light reflectance 27%.
Nearest NCS colour sample S 3030-Y80R.
Grid colour NCS S 3030-Y80R.



RUBY ROCK | Light reflectance 7%.
Nearest NCS colour sample S 4050-R10B.



SAGE GARDEN | Light reflectance 40%.
Nearest NCS colour sample S 3010-B30G.
Grid colour NCS S 3010-B30G.



SILENT STEAM | Light reflectance 45%.
Nearest NCS colour sample S 2010-B.
Grid colour NCS S 2005-R90B.



EUCALYPTUS LEAF | Light reflectance 23%.
Nearest NCS colour sample S 5010-B30G.
Grid colour NCS S 5010-B30G.



FRESH CLOVER | Light reflectance 35%.
Nearest NCS colour sample S 3020-G40Y.
Grid colour NCS S 3020-G40Y.



SCALLOP SHELLS | Light reflectance 76%.
Nearest NCS colour sample S 0804-Y50R.
Grid colour NCS S 0603-Y60R.



SUMMER FOREST | Light reflectance 10%.
Nearest NCS colour sample S 6030-G10Y.
Grid colour NCS S 6030-G10Y.



WET SAND | Light reflectance 35%.
Nearest NCS colour sample S 3020-Y30R.
Grid colour NCS S 3020-Y40R.



DARK DIAMOND | Light reflectance 4%.
Nearest NCS colour sample S 9000-N.
Grid colour NCS S 8000-N.

NOTE

MASTER RIGID is only available in colour White Frost.

Colours may vary slightly between different production batches.

Reproduction of colours vary between print and reality.

ECOPHON MASTER OVERVIEW

Edge design	Product	Absorption class	Connect grid	Sizes (mm)	Ecophon Lighting	Possible combinations
	Ecophon Master A	A	T15 / T24	600x600x40 1200x600x40 1200x1200x40		
	Ecophon Master B	A	Direct fixing	600x600x40 1200x600x40		
	Ecophon Master Ds	A	T24	600x600x40		
	Ecophon Master E	A	T24	600x600x40 1200x600x40 1200x1200x40		
	Ecophon Master Eg	A	T24	600x600 1200x600 1200x1200 2400x600	Ecophon Dot Ecophon Square 43	
	Ecophon Master F	A	Direct fixing	600x600x40 1200x600x40		
	Ecophon Master SQ	A	Direct fixing	600x600x40 1200x600x40		
	Ecophon Master Rigid A	A	T24	600x600x20 1200x600x20 1600x600x20 1800x600x20 2000x600x20 2400x600x20		Extra Bass 1200x600
	Ecophon Master Rigid E	A	T24	600x600x20 1200x600x20 1200x1200x20		Extra Bass 1200x600
	Ecophon Master Rigid Dp	A	T24	600x600x20 1200x600x20		Extra Bass 1200x600



Ecophon Master panels contribute to a healthy indoor environment with superior acoustic absorption, low VOC emissions in line with the strictest requirements, and a full chemical transparency with verified Health Product Declarations. The low environmental footprint of our Master panels is third-party verified in Environmental Product Declarations.



For projects where environmental excellence is a priority, Ecophon offers you the Plant option, specifically designed to maximise the contribution of the ceiling to green building certification schemes. Our Plant panel range features bio-based materials, an industry-low CO₂ footprint and the lowest indoor air emissions, with the Eurofins Indoor Air Comfort Gold certification.

The products do not contribute to fire and the glass wool core of the Master tiles is tested and classified as non-combustible according to EN ISO 1182. Fire classification according to EN 13501-1, see Technical Properties on respectively product.

NOTE

More product and system information such as installation help and sustainability documentation can be found at www.ecophon.com



Ecophon Master A Ecophon Master B Ecophon Master Ds Ecophon Master E Ecophon Master Eg Ecophon Master F



Ecophon Master SQ Ecophon Master Rigid A Ecophon Master Rigid E Ecophon Master Rigid Dp



System properties

ACOUSTICS, TECHNICAL PROPERTIES AND INSTALLATION DIAGRAMS

- 26 Master A
- 28 Master B
- 30 Master Ds
- 32 Master E
- 34 Master Eg
- 36 Master F
- 38 Master SQ
- 40 Master Rigid A
- 42 Master Rigid E
- 44 Master Rigid Dp
- 46 Ecophon Extra Bass
- 48 Square 43
- 49 Dot



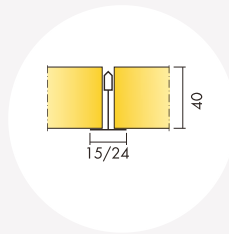

Ecophon Master™ A

Acoustics:

Sound Absorption:

Test results according to EN ISO 354. Classification according to EN ISO 11654, and the single value ratings for Noise Reduction Coefficient, NRC and Sound Absorption Average, SAA according to ASTM C 423.

α_p , Practical sound absorption coefficient

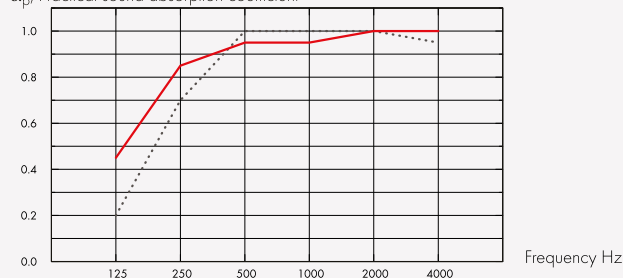

--- Master A 40 mm, 50 mm o.d.s.
 - - Master A 40 mm, 200 mm o.d.s.
 o.d.s = overall depth of system

THK mm	o.d.s. mm	α_p , Practical sound absorption coefficient						α_w	Sound absorption class
		125 Hz	250 Hz	500 Hz	1000 Hz	2000 Hz	4000 Hz		
40	50	0.20	0.70	1.00	1.00	1.00	0.95	1.00	A
40	200	0.45	0.85	0.95	0.95	1.00	1.00	1.00	A

	THK mm	o.d.s. mm	NRC	SAA
-	40	50	1.00	1.00
-	40	400	0.95	0.93

THK mm	AC(1,5)		D_{nfw}		CAC dB	
	Articulation Class, ASTM E1111, ASTM E1110		Weighted normalized flanking level difference, ISO 10848-2		Ceiling Attenuation Class, ASTM 1414, ASTM E413	
40	200		28		30	

Indoor Air Quality:

Certificate / Label	Standard	Plant
Eurofins Indoor Air Comfort®	IAC	IAC Gold
French VOC	A	A+
Finnish M1	•	•

Environmental Footprint: Life-cycle stages A1 to C4 from EPD, in conformity with ISO 14025 / EN 15792 Master A: 3,70 , Master A/Plant: 3,09 ,

Circularity: Minimum post-consumer recycled content: 59%, Recyclability: Fully recyclable,

Fire safety: The glass wool core of the tiles is tested and classified as non-combustible according to EN ISO 1182. Europe: EN 13501-1, A2-s1,d0,

Humidity Resistance: According to EN 13964:2014 Standard: Class C, RH 95% and 30°C, Plant: Class A, RH 70% and 25°C,

Visual appearance: White Frost, nearest NCS colour sample S 0500-N, 85% light reflectance. Gloss < 1.

Cleanability: Daily dusting and vacuum cleaning. Weekly wet wiping.

Accessibility: The tiles are easily demountable. Minimum demounting depth according to installation diagrams.

Installation: Installed according to installation diagrams, installation guides and drawing aid. For information regarding minimum overall depth of system see quantity specification.

System weight: The weight of the system (including suspension grid) should be approximately 5 kg/m².

Mechanical properties: See table about Max live load and Min load bearing capacity and Functional demands, Mechanical properties at www.ecophon.com.

CE: Ecophon ceiling systems are CE marked according to the European harmonized standard EN13964:2014. CE marked construction products are covered by a Declaration of Performance (DOP) which enables customers and users to easily compare performance of products available on the European market.

Installation diagram in detail www.ecophon.com

M56

Installation diagram (M56) for Ecophon Master A

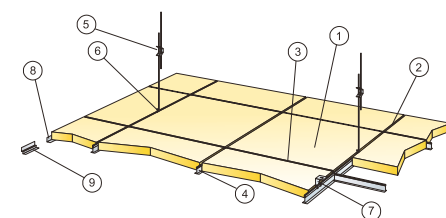

© Ecophon Group

M56QL

Installation diagram (M56) for Ecophon Master A with Quick-Lock grid system

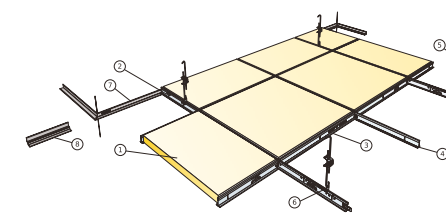

M56 DIN

Installation diagram (M56 DIN) for Ecophon Master A

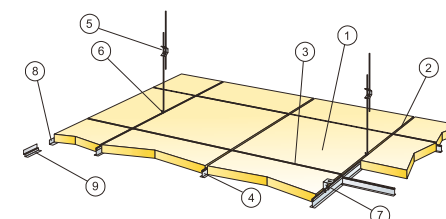

© Ecophon Group

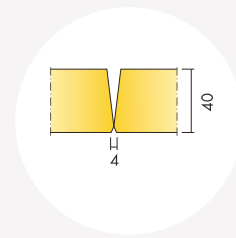

Ecophon Master™ B

Acoustics:

Sound Absorption:

Test results according to EN ISO 354. Classification according to EN ISO 11654, and the single value ratings for Noise Reduction Coefficient, NRC and Sound Absorption Average, SAA according to ASTM C 423.

α_p , Practical sound absorption coefficient

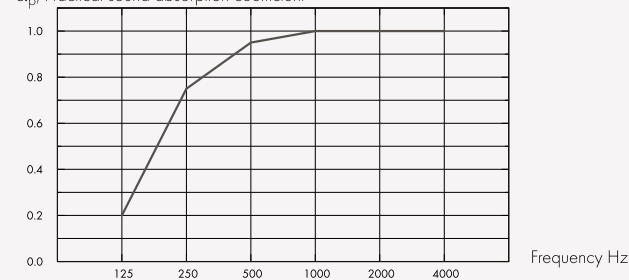

– Master B 40 mm, 43 mm o.d.s.
o.d.s = overall depth of system

THK mm	o.d.s. mm	α_p , Practical sound absorption coefficient						α_w	Sound absorption class
		125 Hz	250 Hz	500 Hz	1000 Hz	2000 Hz	4000 Hz		
40	43	0.20	0.75	0.95	1.00	1.00	1.00	1.00	A

THK mm	o.d.s. mm	NRC	SAA
40	43	0.95	0.93

Indoor Air Quality:

Certificate / Label

Eurofins Indoor Air Comfort®	IAC
French VOC	A
Finnish M1	•

Indoor Air Quality:

Certificate / Label

In collaboration with the Allergy, Skin and Asthma Association

Environmental Footprint: Life-cycle stages A1 to C4 from EPD, in conformity with ISO 14025 / EN 15830 Master B: 7,30,

Circularity: Minimum post-consumer recycled content: 62%, Recyclability: Fully recyclable,

Fire safety: The glass wool core of the tiles is tested and classified as non-combustible according to EN ISO 1182. Europe: EN 13501-1, A2-s1,d0,

Humidity Resistance: Class C, relative humidity 95% and 30°C, according to EN 13964:2014

Visual appearance: White Frost, nearest NCS colour sample S 0500-N, 85% light reflectance. Gloss < 1.

Cleanability: Daily dusting and vacuum cleaning. Weekly wet wiping.

Accessibility: The tiles are not demountable.

Installation: Installed according to installation diagrams, installation guides and drawing aid. For information regarding minimum overall depth of system see quantity specification. Rendered surfaces must have sufficient strength to be able to carry the load imposed by the tiles. If doubts, test gluing should be carried out. The surface should always be dry and clean. For best result the surface should be even.

System weight: The weight of the system should be approximately 5 kg/m².

Mechanical properties: Additional live load has to be fixed to the soffit.

CE: Ecophon ceiling systems are CE marked according to the European harmonized standard EN 13964:2014. CE marked construction products are covered by a Declaration of Performance (DOP) which enables customers and users to easily compare performance of products available on the European market.

Installation diagram in detail www.ecophon.com

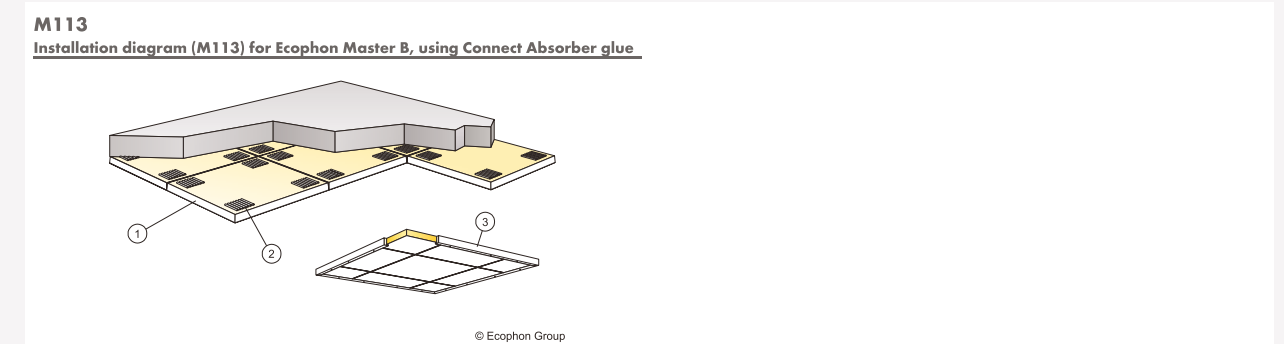

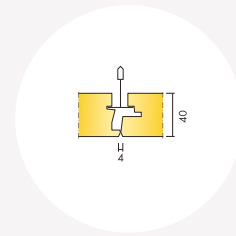

Ecophon Master™ Ds

Acoustics:

Sound Absorption:

Test results according to EN ISO 354. Classification according to EN ISO 11654, and the single value ratings for Noise Reduction Coefficient, NRC and Sound Absorption Average, SAA according to ASTM C 423.

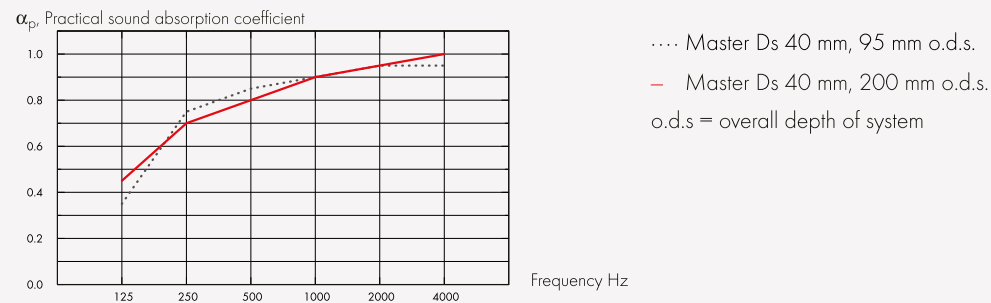

THK mm	o.d.s. mm	α_p Practical sound absorption coefficient						α_w	Sound absorption class
		125 Hz	250 Hz	500 Hz	1000 Hz	2000 Hz	4000 Hz		
40	95	0.35	0.75	0.85	0.90	0.95	0.95	0.90	A
40	200	0.45	0.70	0.80	0.90	0.95	1.00	0.90	A

	THK mm	o.d.s. mm	NRC	SAA
-	40	95	0.90	0.91
-	40	400	0.85	0.86

THK mm	AC(1.5)		D_{nfw}		CAC dB	
	Articulation Class, ASTM E1111, ASTM E1110		Weighted normalized flanking level difference, ISO 10848-2		Ceiling Attenuation Class, ASTM 1414, ASTM E413	
40	200		31		33	

Indoor Air Quality:

Certificate / Label

Eurofins Indoor Air Comfort®	IAC
French VOC	A
Finnish M1	•

Indoor Air Quality:

Certificate / Label

In collaboration with the Allergy, Skin and Asthma Association

Environmental Footprint: Life-cycle stages A1 to C4 from EPD, in conformity with ISO 14025 / EN 15849 Master Ds: 7,10,

Environmental Footprint: Kg CO₂ equiv/m²: 7,10 From EPD in conformity with ISO 14025 / EN 15804

Circularity: Minimum post-consumer recycled content: 63%, Recyclability: Fully recyclable,

Fire safety: The glass wool core of the tiles is tested and classified as non-combustible according to EN ISO 1182. Europe: EN 13501-1, A2-s1,d0,

Humidity Resistance: Class C, relative humidity 95% and 30°C, according to EN 13964:2014

Visual appearance: White Frost, nearest NCS colour sample S 0500-N, 85% light reflectance. Gloss < 1.

Cleanability: Daily dusting and vacuum cleaning. Weekly wet wiping.

Accessibility: The tiles are easily demountable. Minimum demounting depth according to installation diagrams.

Installation: Installed according to installation diagrams, installation guides and drawing aid. For information regarding minimum overall depth of system see quantity specification. The systems are not recommended for small rooms (approximately 2x2 m²). Ceilings with a large amount of integrations require careful planning, design and installation.

System weight: The weight of the system (including suspension grid) should be approximately 6 kg/m².

Mechanical properties: See table about Max live load and Min load bearing capacity and Functional demands, Mechanical properties at www.ecophon.com.

CE: Ecophon ceiling systems are CE marked according to the European harmonized standard EN13964:2014. CE marked construction products are covered by a Declaration of Performance (DOP) which enables customers and users to easily compare performance of products available on the European market.

Installation diagram in detail www.ecophon.com

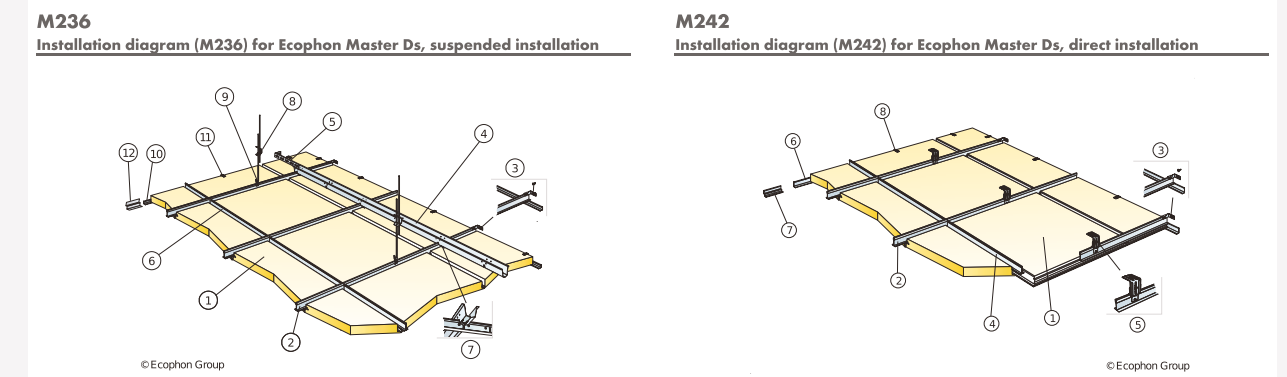

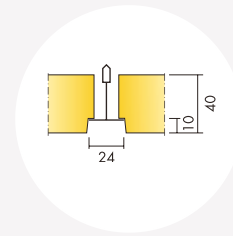

Ecophon Master™ E

Acoustics:

Sound Absorption:

Test results according to EN ISO 354. Classification according to EN ISO 11654, and the single value ratings for Noise Reduction Coefficient, NRC and Sound Absorption Average, SAA according to ASTM C 423.

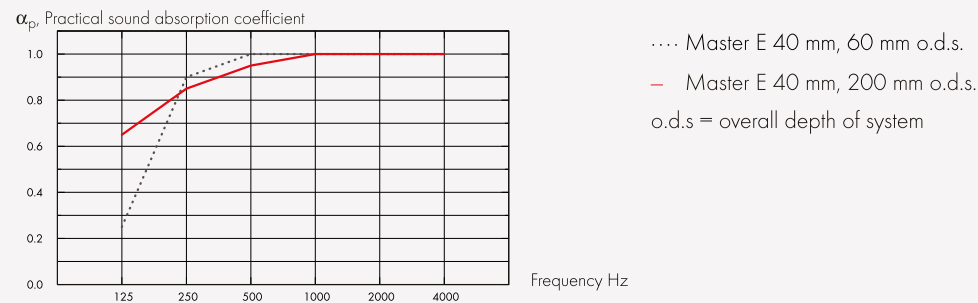

THK mm	o.d.s. mm	α_p Practical sound absorption coefficient						α_w	Sound absorption class
		125 Hz	250 Hz	500 Hz	1000 Hz	2000 Hz	4000 Hz		
40	60	0.25	0.90	1.00	1.00	1.00	1.00	A	
40	200	0.65	0.85	0.95	1.00	1.00	1.00	A	

	THK mm	o.d.s. mm	NRC	SAA
-	40	60	1.00	0.98
-	40	200	0.95	0.97
-	40	400	0.90	0.89

THK mm	AC(1.5) Articulation Class, ASTM E1111, ASTM E1110	D_{nfw} Weighted normalized flanking level difference, ISO 10848-2	CAC dB Ceiling Attenuation Class, ASTM 1414, ASTM E413
40	200	29	31

Indoor Air Quality:

Certificate / Label	Standard	Plant
Eurofins Indoor Air Comfort®	IAC	IAC Gold
French VOC	A	A+
Finnish M1	•	•

Environmental Footprint: Life-cycle stages A1 to C4 from EPD, in conformity with ISO 14025 / EN 15843 Master E: 6,10, Master E/Plant: 4,15 ,

Circularity: Minimum post-consumer recycled content: 61%, Recyclability: Fully recyclable,

Fire safety: The glass wool core of the tiles is tested and classified as non-combustible according to EN ISO 1182. Europe: EN 13501-1, A2-s1,d0,

Humidity Resistance: According to EN 13964:2014 Standard: Class C, RH 95% and 30°C, Plant: Class A, RH 70% and 25°C,

Visual appearance: White Frost, nearest NCS colour sample S 0500-N, 85% light reflectance. Gloss < 1.

Cleanability: Daily dusting and vacuum cleaning. Weekly wet wiping.

Accessibility: The tiles are easily demountable. Minimum demounting depth according to installation diagrams.

Installation: Installed according to installation diagrams, installation guides and drawing aid. For information regarding minimum overall depth of system see quantity specification.

System weight: The weight of the system (including suspension grid) should be approximately 5 kg/m².

Mechanical properties: See table about Max live load and Min load bearing capacity and Functional demands, Mechanical properties at www.ecophon.com.

CE: Ecophon ceiling systems are CE marked according to the European harmonized standard EN13964:2014. CE marked construction products are covered by a Declaration of Performance (DOP) which enables customers and users to easily compare performance of products available on the European market.

Installation diagram in detail www.ecophon.com

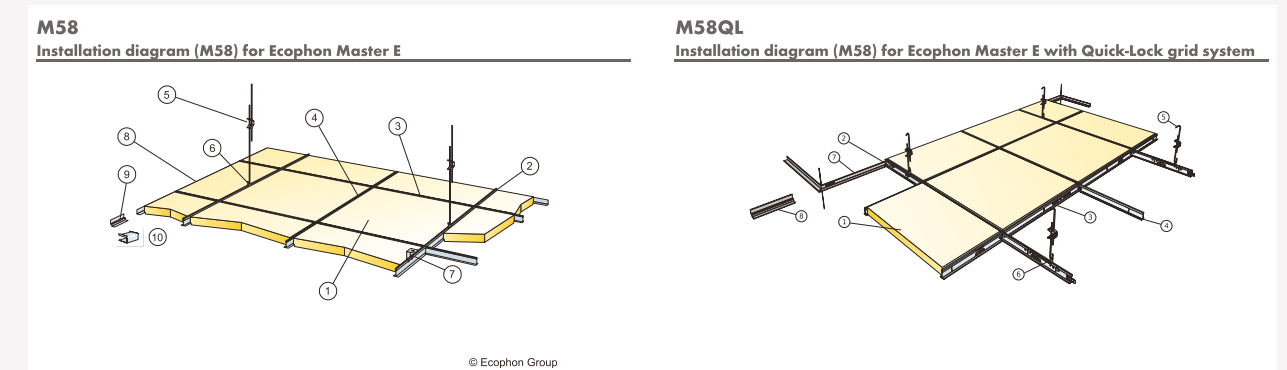

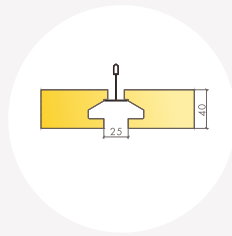

Ecophon Master™ Eg

Acoustics:

Sound Absorption:

Test results according to EN ISO 354. Classification according to EN ISO 11654.

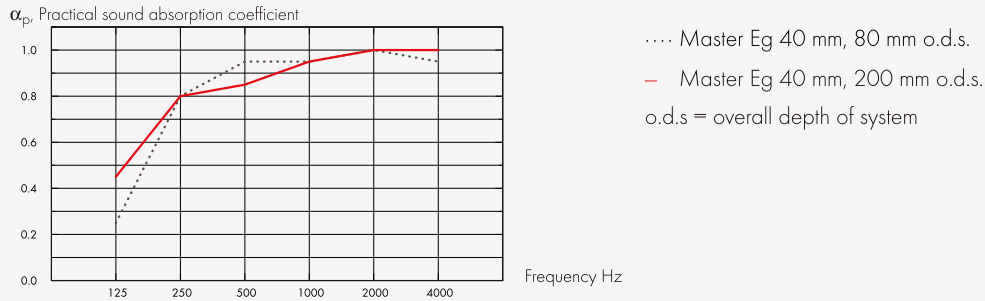

THK mm	o.d.s. mm	α_p Practical sound absorption coefficient						α_w	Sound absorption class
		125 Hz	250 Hz	500 Hz	1000 Hz	2000 Hz	4000 Hz		
40	80	0.25	0.80	0.95	0.95	1.00	0.95	1.00	A
40	200	0.45	0.80	0.85	0.95	1.00	1.00	0.95	A

THK mm	AC(1.5)
40	200

Articulation Class, ASTM E1111, ASTM E1110

Indoor Air Quality:

Certificate / Label

Eurofins Indoor Air Comfort®	IAC
French VOC	A
Finnish M1	•

Indoor Air Quality:

Certificate / Label

In collaboration with the Allergy, Skin and Asthma Association

Environmental Footprint: Life-cycle stages A1 to C4 from EPD, in conformity with ISO 14025 / EN 15835 Master Eg: 6,10 ,

Circularity: Minimum post-consumer recycled content: 61%, Recyclability: Fully recyclable,

Fire safety: The glass wool core of the tiles is tested and classified as non-combustible according to EN ISO 1182. Europe: EN 13501-1, A2-s1,d0,

Humidity Resistance: Class C, relative humidity 95% and 30°C, according to EN 13964:2014

Visual appearance: White Frost, nearest NCS colour sample S 0500-N, 85% light reflectance. Gloss < 1.

Cleanability: Daily dusting and vacuum cleaning. Weekly wet wiping.

Accessibility: The tiles are easily demountable. Minimum demounting depth according to installation diagrams.

Installation: Installed according to installation diagrams, installation guides and drawing aid. For information regarding minimum overall depth of system see quantity specification.

System weight: The weight of the system (including suspension grid) should be approximately 5 kg/m².

Mechanical properties: See table about Max live load and Min load bearing capacity and Functional demands, Mechanical properties at www.ecophon.com.

CE: Ecophon ceiling systems are CE marked according to the European harmonized standard EN 13964:2014. CE marked construction products are covered by a Declaration of Performance (DOP) which enables customers and users to easily compare performance of products available on the European market.

Installation diagram in detail www.ecophon.com

M498

Installation diagram (M498) for Ecophon Master Eg

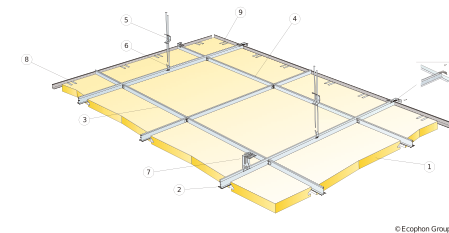

M499

Installation diagram (M499) for Ecophon Master Eg

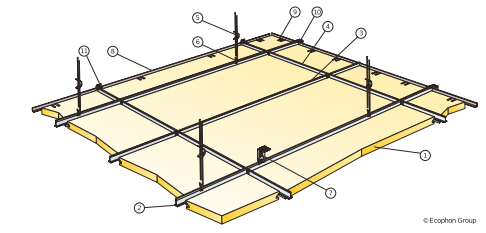

M500

Installation diagram (M500) for Ecophon Master Eg

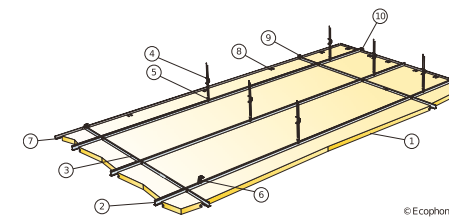

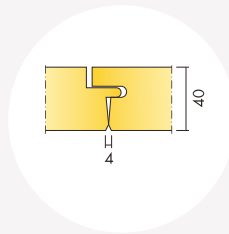

Ecophon Master™ F

Acoustics:

Sound Absorption:

Test results according to EN ISO 354. Classification according to EN ISO 11654, and the single value ratings for Noise Reduction Coefficient, NRC and Sound Absorption Average, SAA according to ASTM C 423.

α_p , Practical sound absorption coefficient

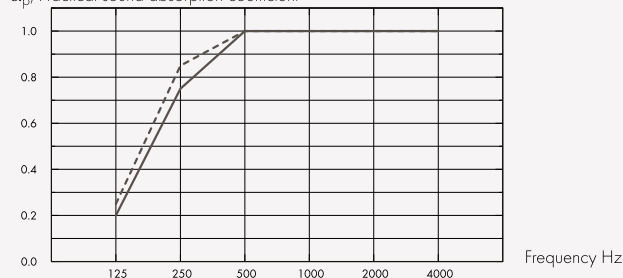

— Master F 40 mm, 40 mm o.d.s.
 --- Master F 40 mm, 60 mm o.d.s.
 o.d.s = overall depth of system

THK mm	o.d.s. mm	α_p , Practical sound absorption coefficient						α_w	Sound absorption class
		125 Hz	250 Hz	500 Hz	1000 Hz	2000 Hz	4000 Hz		
40	40	0.20	0.75	1.00	1.00	1.00	1.00	1.00	A
40	60	0.25	0.85	1.00	1.00	1.00	1.00	1.00	A

	THK mm	o.d.s. mm	NRC	SAA
-	40	40	0.95	0.96
-	40	60	0.95	0.98

Indoor Air Quality:

Certificate / Label

Eurofins Indoor Air Comfort®	IAC
French VOC	A
Finnish M1	•

Indoor Air Quality:

Certificate / Label

In collaboration with the Allergy, Skin and Asthma Association

Environmental Footprint: Life-cycle stages A1 to C4 from EPD, in conformity with ISO 14025 / EN 15795 Master F: 7,30 ,

Circularity: Minimum post-consumer recycled content: 63%, Recyclability: Fully recyclable,

Fire safety: The glass wool core of the tiles is tested and classified as non-combustible according to EN ISO 1182. Europe: EN 13501-1, A2-s1,d0,

Humidity Resistance: Class C, relative humidity 95% and 30°C, according to EN 13964:2014

Visual appearance: White Frost, nearest NCS colour sample S 0500-N, 85% light reflectance. Gloss < 1.

Cleanability: Daily dusting and vacuum cleaning. Weekly wet wiping.

Accessibility: The tiles are not demountable.

Installation: Installed according to installation diagrams, installation guides and drawing aid. For information regarding minimum overall depth of system see quantity specification. For best result the surface should be even, however an acceptable result could be achieved on slightly uneven surfaces. If very uneven surfaces – installation of furring (evenly spaced timber battens) as the substrate for the tiles is recommended.

System weight: The weight of the system should be approximately 5 kg/m².

Mechanical properties: Additional live load has to be fixed to the soffit.

CE: Ecophon ceiling systems are CE marked according to the European harmonized standard EN 13964:2014. CE marked construction products are covered by a Declaration of Performance (DOP) which enables customers and users to easily compare performance of products available on the European market.

Installation diagram in detail www.ecophon.com

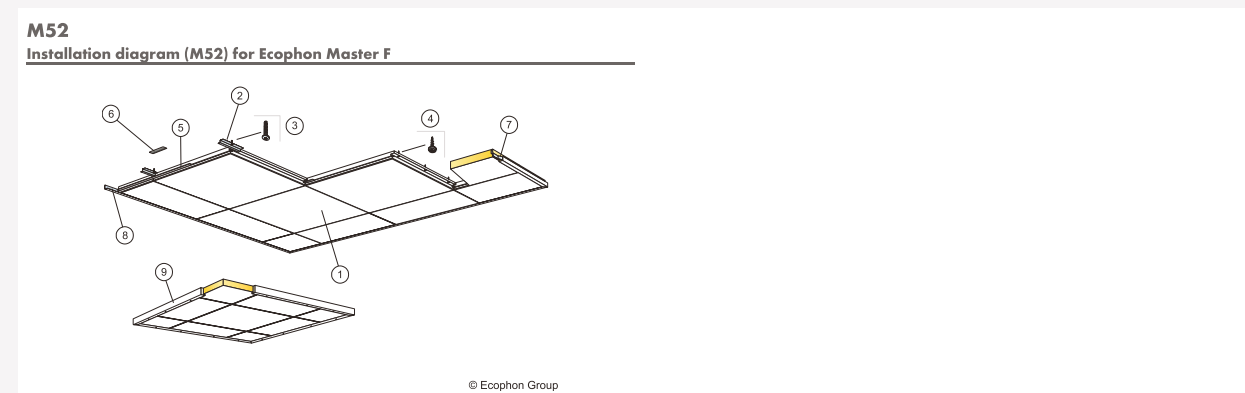

© Ecophon Group

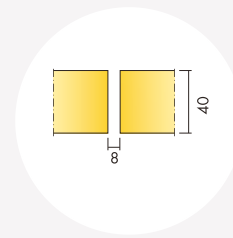

Ecophon Master™ SQ

Acoustics:

Sound Absorption:

Test results according to EN ISO 354. Classification according to EN ISO 11654.

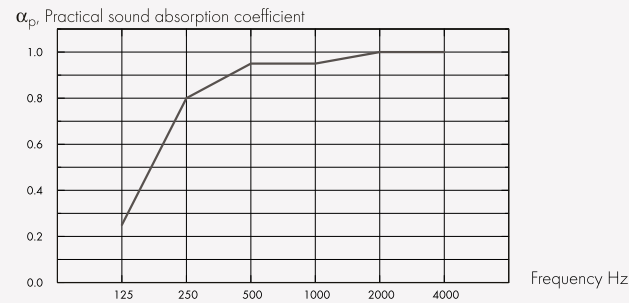

– Master SQ 40 mm, 43 mm o.d.s.
o.d.s = overall depth of system

THK mm	o.d.s. mm	α_p Practical sound absorption coefficient						α_w	Sound absorption class
		125 Hz	250 Hz	500 Hz	1000 Hz	2000 Hz	4000 Hz		
40	43	0.25	0.80	0.95	0.95	1.00	1.00	1.00	A

Indoor Air Quality:

Certificate / Label

Eurofins Indoor Air Comfort®	IAC
French VOC	A
Finnish M1	•

Environmental Footprint: Life-cycle stages A1 to C4 from EPD, in conformity with ISO 14025 / EN 15864 Master SQ: 7,20,

Circularity: Minimum post-consumer recycled content: 62%, Recyclability: Fully recyclable,

Fire safety: The glass wool core of the tiles is tested and classified as non-combustible according to EN ISO 1182. Europe: EN 13501-1, A2-s1,d0,

Humidity Resistance: Class C, relative humidity 95% and 30°C, according to EN 13964:2014

Visual appearance: White Frost, nearest NCS colour sample S 0500-N, 85% light reflectance. Gloss < 1.

Cleanability: Daily dusting and vacuum cleaning. Weekly wet wiping.

Accessibility: The tiles are not demountable.

Installation: Installed according to installation diagrams, installation guides and drawing aid. For information regarding minimum overall depth of system see quantity specification. Rendered surfaces must have sufficient strength to be able to carry the load imposed by the tiles. If doubts, test gluing should be carried out. The surface should always be dry and clean. For best result the surface should be even, however an acceptable result could be achieved on slightly uneven surfaces.

System weight: The weight of the system should be approximately 5 kg/m².

Mechanical properties: Additional live load has to be fixed to the soffit.

CE: Ecophon ceiling systems are CE marked according to the European harmonized standard EN13964:2014. CE marked construction products are covered by a Declaration of Performance (DOP) which enables customers and users to easily compare performance of products available on the European market.

Installation diagram in detail www.ecophon.com

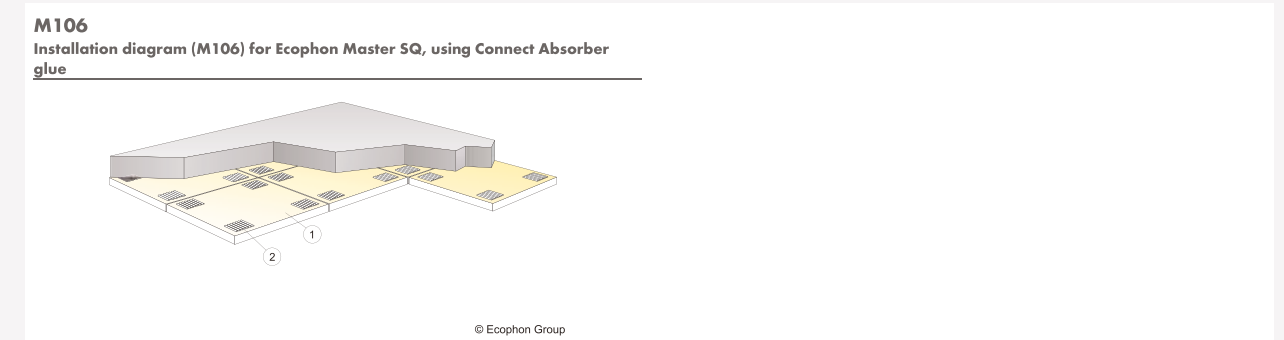

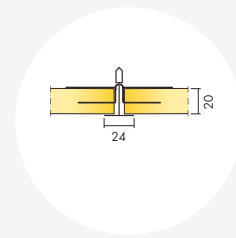

Ecophon Master™ Rigid A

Acoustics:

Sound Absorption:

Test results according to EN ISO 354. Classification according to EN ISO 11654.

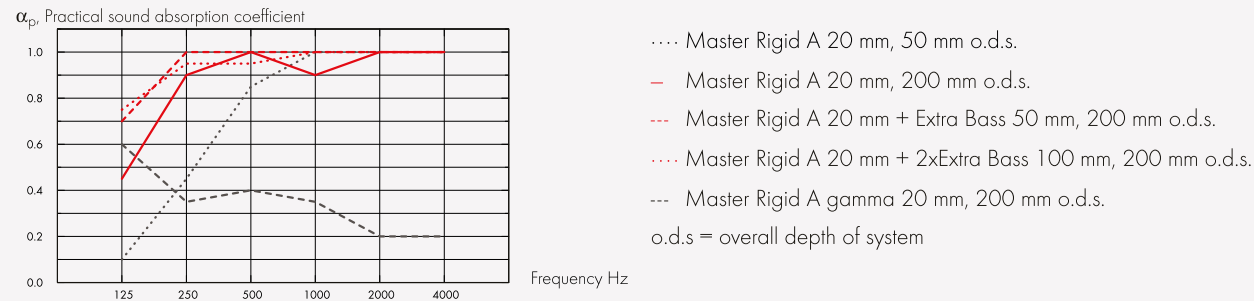

	THK mm	o.d.s. mm	α_p , Practical sound absorption coefficient					α_w	Sound absorption class	
			125 Hz	250 Hz	500 Hz	1000 Hz	2000 Hz			4000 Hz
-	20	50	0.10	0.45	0.85	1.00	1.00	1.00	0.75	C
-	20	200	0.45	0.90	1.00	0.90	1.00	1.00	1.00	A
+ Extra Bass	70	200	0.70	1.00	1.00	1.00	1.00	1.00	1.00	A
+ 2xExtra Bass	120	200	0.75	0.95	0.95	1.00	1.00	1.00	1.00	A
gamma	20	200	0.60	0.35	0.40	0.35	0.20	0.20	0.30	D

	THK mm	o.d.s. mm	NRC	SAA
-	20	50	0.80	0.83
-	20	200	0.95	0.93
+ Extra Bass	70	200	1.00	1.00
gamma	20	200	0.35	0.33

Indoor Air Quality:

Certificate / Label

Eurofins Indoor Air Comfort®	IAC
French VOC	A
Finnish M1	•

Indoor Air Quality:

Certificate / Label

In collaboration with the Allergy, Skin and Asthma Association

Environmental Footprint: Life-cycle stages A1 to C4 from EPD, in conformity with ISO 14025 / EN 15859 Master Rigid A: 2,95 ,

Circularity: Minimum post-consumer recycled content: 46%, Recyclability: Fully recyclable,

Fire safety: The glass wool core of the tiles is tested and classified as non-combustible according to EN ISO 1182. Europe: EN 13501-1, A2-s1,d0,

Humidity Resistance: Class C, relative humidity 95% and 30°C, according to EN 13964:2014

Visual appearance: White Frost, nearest NCS colour sample S 0500-N, 85% light reflectance. Gloss < 1.

Cleanability: Daily dusting and vacuum cleaning. Weekly wet wiping.

Accessibility: The tiles are secured in the grid, but demountable. Minimum demounting depth according to installation diagrams.

Installation: Installed according to installation diagrams, installation guides and drawing aid. For information regarding minimum overall depth of system see quantity specification.

System weight: The weight of the system (including suspension grid and Extra Bass) should be approximately 3,5 kg/m².

Mechanical properties: See table regarding the min- and max- load bearing capacities and functional demands.

Impact Resistance: Tested and classified according to EN 13964 annex D. M316: 3A,

CE: Ecophon ceiling systems are CE marked according to the European harmonized standard EN 13964:2014. CE marked construction products are covered by a Declaration of Performance (DOP) which enables customers and users to easily compare performance of products available on the European market.

Installation diagram in detail www.ecophon.com

M316EB

Installation diagram (M316EB) for Ecophon Master Rigid A

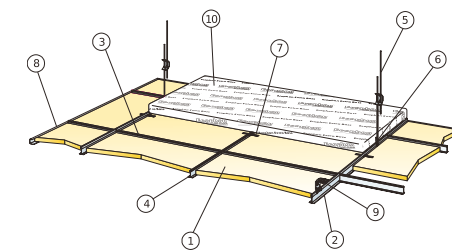

© Ecophon Group

M316EB DIN

Installation diagram (M316EB DIN) for Ecophon Master Rigid A

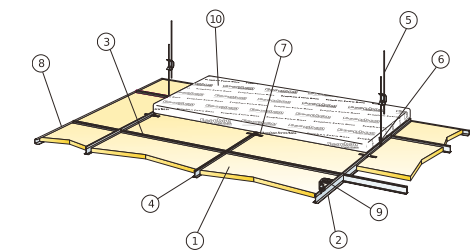

© Ecophon Group

M333

Installation diagram (M333) for Ecophon Master Rigid A XL in corridors

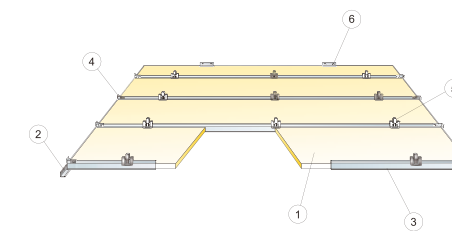

© Ecophon Group

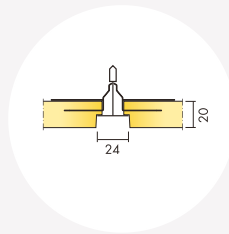

Ecophon Master™ Rigid E

Acoustics:

Sound Absorption:

Test results according to EN ISO 354. Classification according to EN ISO 11654.

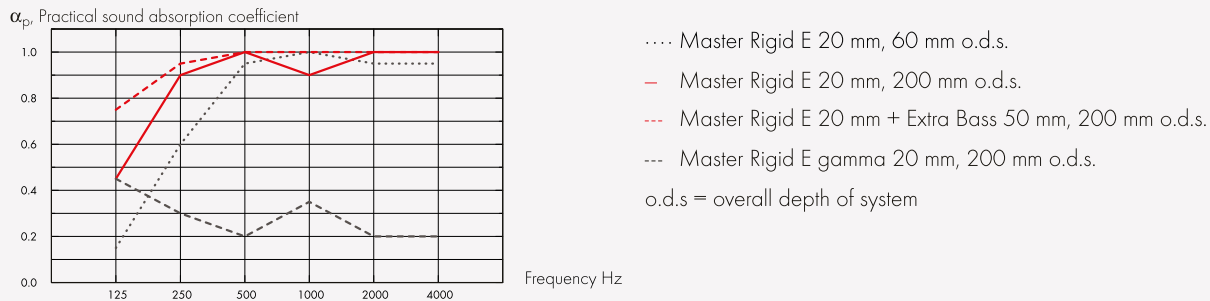

	THK mm	o.d.s. mm	α_p , Practical sound absorption coefficient						α_w	Sound absorption class
			125 Hz	250 Hz	500 Hz	1000 Hz	2000 Hz	4000 Hz		
-	20	60	0.15	0.60	0.95	1.00	0.95	0.95	0.90	A
-	20	200	0.45	0.90	1.00	0.90	1.00	1.00	1.00	A
+ Extra Bass	70	200	0.75	0.95	1.00	1.00	1.00	1.00	1.00	A
gamma	20	200	0.45	0.30	0.20	0.35	0.20	0.20	0.25	E

Indoor Air Quality:

Certificate / Label

Eurofins Indoor Air Comfort®	IAC
French VOC	A
Finnish M1	•

Indoor Air Quality:

Certificate / Label

In collaboration with the Allergy, Skin and Asthma Association

Environmental Footprint: Life-cycle stages A1 to C4 from EPD, in conformity with ISO 14025 / EN 15801 Master Rigid E: 3,27 ,

Circularity: Minimum post-consumer recycled content: 45%, Recyclability: Fully recyclable,

Fire safety: The glass wool core of the tiles is tested and classified as non-combustible according to EN ISO 1182. Europe: EN 13501-1, A2-s1,d0,

Humidity Resistance: Class C, relative humidity 95% and 30°C, according to EN 13964:2014

Visual appearance: White Frost, nearest NCS colour sample S 0500-N, 85% light reflectance. Gloss < 1.

Cleanability: Daily dusting and vacuum cleaning. Weekly wet wiping.

Accessibility: The tiles are secured in the grid, but demountable. Minimum demounting depth according to installation diagrams.

Installation: Installed according to installation diagrams, installation guides and drawing aid. For information regarding minimum overall depth of system see quantity specification.

System weight: The weight of the system (including suspension grid) should be approximately 5 kg/m².

Mechanical properties: See table regarding the min- and max- load bearing capacities and functional demands.

Impact Resistance: Tested and classified according to EN 13964 annex D. M317: 3A,

CE: Ecophon ceiling systems are CE marked according to the European harmonized standard EN 13964:2014. CE marked construction products are covered by a Declaration of Performance (DOP) which enables customers and users to easily compare performance of products available on the European market.

Installation diagram in detail www.ecophon.com

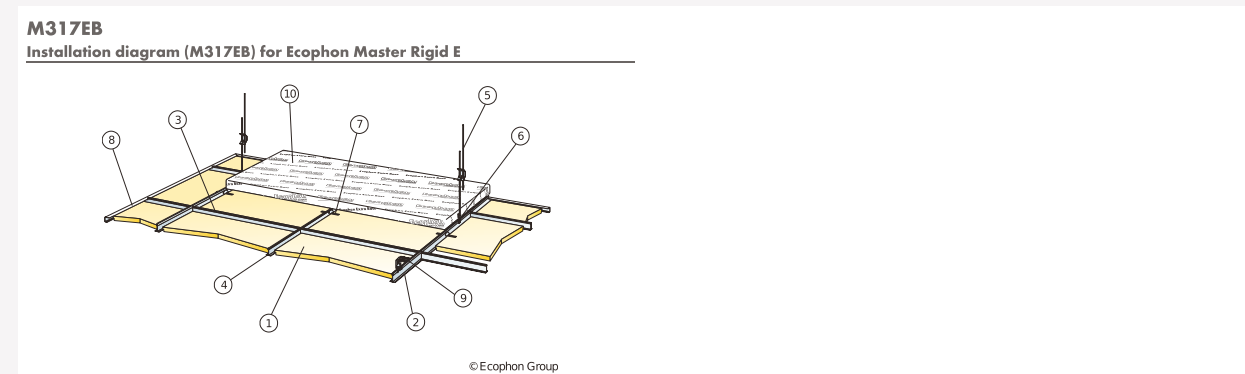

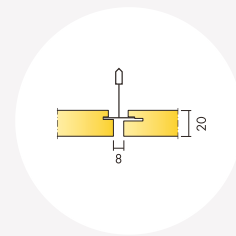

Ecophon Master™ Rigid Dp

Acoustics:

Sound Absorption:

Test results according to EN ISO 354. Classification according to EN ISO 11654.

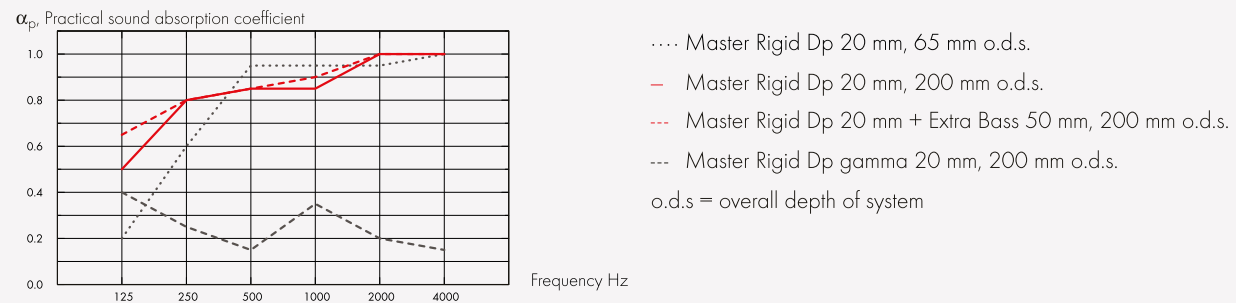

	THK mm	o.d.s. mm	α_p , Practical sound absorption coefficient						α_w	Sound absorption class
			125 Hz	250 Hz	500 Hz	1000 Hz	2000 Hz	4000 Hz		
-	20	65	0.20	0.60	0.95	0.95	0.95	1.00	0.90	A
-	20	200	0.50	0.80	0.85	0.85	1.00	1.00	0.90	A
+ Extra Bass	70	200	0.65	0.80	0.85	0.90	1.00	1.00	0.90	A
gamma	20	200	0.40	0.25	0.15	0.35	0.20	0.15	0.20	E

Indoor Air Quality:

Certificate / Label

Eurofins Indoor Air Comfort®	IAC
French VOC	A
Finnish M1	•

Indoor Air Quality:

Certificate / Label

In collaboration with the Allergy, Skin and Asthma Association

Environmental Footprint: Life-cycle stages A1 to C4 from EPD, in conformity with ISO 14025 / EN 15836 Master Rigid Dp: 4,95, Extra Bass: 1,62 ,

Circularity: Minimum post-consumer recycled content: 55%, Recyclability: Fully recyclable,

Fire safety: The glass wool core of the tiles is tested and classified as non-combustible according to EN ISO 1182. Europe: EN 13501-1, A2-s1,d0,

Humidity Resistance: Class C, relative humidity 95% and 30°C, according to EN 13964:2014

Visual appearance: White Frost, nearest NCS colour sample S 0500-N, 85% light reflectance. Gloss < 1.

Cleanability: Daily dusting and vacuum cleaning. Weekly wet wiping.

Accessibility: The tiles are secured in the grid, but demountable. Minimum demounting depth according to installation diagrams.

Installation: Installed according to installation diagrams, installation guides and drawing aid. For information regarding minimum overall depth of system see quantity specification.

System weight: The weight of the system (including suspension grid and Extra Bass) should be approximately 4 kg/m².

Mechanical properties: See table regarding the min- and max- load bearing capacities and functional demands.

Impact Resistance: Tested and classified according to EN 13964 annex D. M318: 3A,

CE: Ecophon ceiling systems are CE marked according to the European harmonized standard EN13964:2014. CE marked construction products are covered by a Declaration of Performance (DOP) which enables customers and users to easily compare performance of products available on the European market.

Installation diagram in detail www.ecophon.com

M318EB
Installation diagram (M318EB) for Ecophon Master Rigid Dp

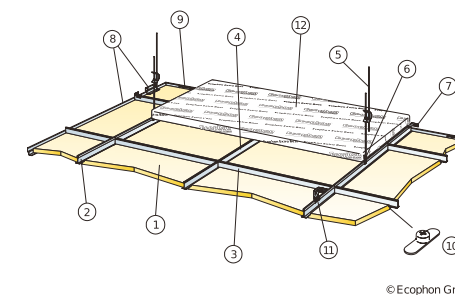

M319
Installation diagram (M319) for Ecophon Master Rigid Dp in corridors

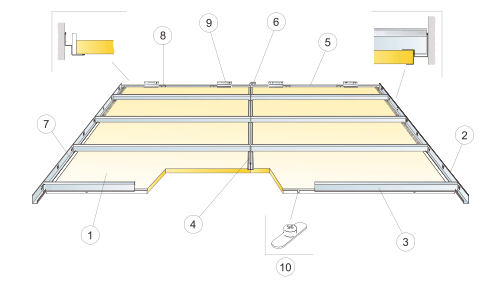

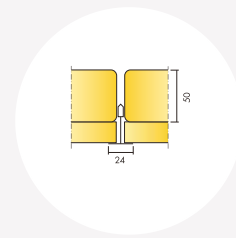

Ecophon Extra Bass

Acoustics: Addition of Extra Bass on top of Ecophon ceiling systems will give increased absorption in low frequencies. For detailed information please see systems for Master Rigid and Gedina + Extra Bass.

Indoor Air Quality:

Certificate / Label

Eurofins Indoor Air Comfort®	IAC
French VOC	A
Finnish M1	•

Environmental Footprint: Kg CO₂ equiv/m²: 1,62 From EPD in conformity with ISO 14025 / EN 15804

Circularity: Fully recyclable

Fire safety: The glass wool core of the tiles is tested and classified as non-combustible according to EN ISO 1182. The reaction-to-fire classification is referring to Master Rigid systems (Master Rigid + Extra Bass) and Gedina + Extra Bass. Europe: EN 13501-1, A2-s1,d0,

Humidity Resistance: Class C, RH 95% and 30°C:

Visual appearance: Not applicable.

Cleanability: Not applicable.

Accessibility: The product is easily installed, and can be folded around installations in the plenum. Minimum demounting depth according to installation diagrams for the Master Rigid and Gedina + Extra Bass systems.

Installation: Installed according to installation diagrams and installation guides for Master Rigid and Gedina + Extra Bass systems. For information regarding minimum overall depth of system see quantity specification.

System weight: The weight of the system (including suspension grid and Extra Bass) should be approximately 3,5 kg/m².

Mechanical properties: Not applicable.

CE: Ecophon ceiling systems are CE marked according to the European harmonized standard EN13964:2014. CE marked construction products are covered by a Declaration of Performance (DOP) which enables customers and users to easily compare performance of products available on the European market.

Installation diagram in detail www.ecophon.com

M323

Installation diagram (M323) for Ecophon Extra Bass

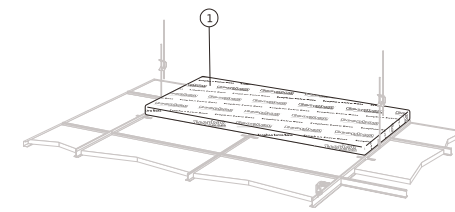

© Ecophon Group

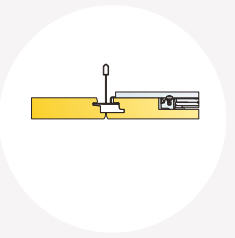
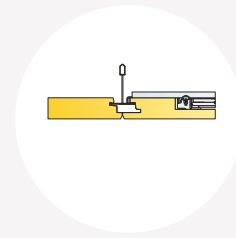

Ecophon Square 43™

Lighting performance:

System effect: 27 W
 Light source: LED 24,5 W
 Luminous flux Square Dg, Ds, E: 3281 lm
 Luminous flux Square Eg, Ez: 2898 lm
 Light efficiency Square Dg, Ds, E: 121,4 lm/W
 Light efficiency Square Dg, Ds, E: 108 lm/W
 Colour temperature: 4000K
 Color rendering index: Ra ≥80
 Colour tolerance: MacAdam ≤3 SDCM
 Light output ratio (LOR): 100%
 Light distribution up/down: 0/100
 Expected lifespan: L90 >50 000 h
 Expected lifespan: L70 >100 000 h

Connection: The standard on/off electronic HF ballast delivered with 2,5 meters of cable 3x0,75 mm² and Euro plugg. The SwitchDIM/DALI delivered without cable.

Electrical data: 220-240 V, 50-60 Hz, power factor cos φ>0,98. Electronic HF ballast or electronic HF dim ballast for digital regulation. Light source: led module of 27W total.

Electrical approvals: IP20, Class 1.

Visual appearance: Tile surface finish; White Frost, nearest NCS colour sample S 0500-N, 85% light reflectance. Gloss < 1.

Cleanability: Daily dusting and vacuum cleaning. Weekly wet wiping.

Accessibility: The tiles are easily demountable. Minimum demounting depth according to installation diagrams.

Installation: Installed according to system range which include information regarding minimum overall depth of system. The tile with luminaire housing rests on the T-profiles and the SwitchDIM/DALI and standard on/off ballasts are fastened to the grid or tile next to the luminaire with velcro. Once the tile with luminaire and ballast are in place a certified installation electrician must connect the wiring to sockets or to the next luminaire.

Installation diagram in detail www.ecophon.com

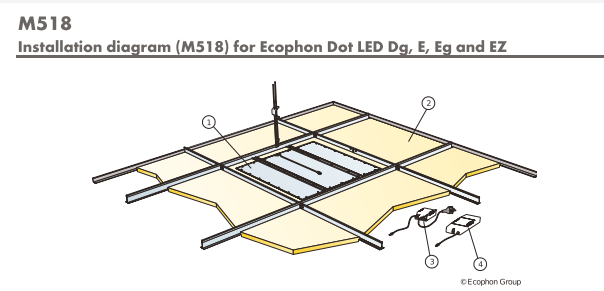
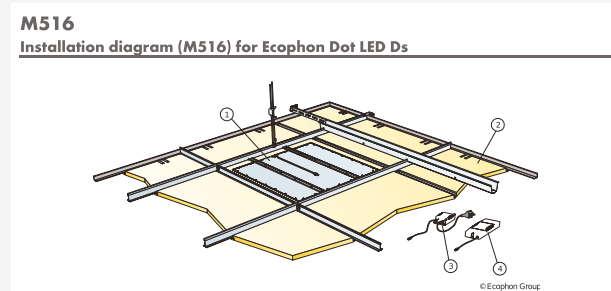

Ecophon Dot™

Lighting performance:

System effect: 27 W
 Light source: LED 24,5 W
 Luminous flux Dot Dg, Ds, E: 2936 lm
 Luminous flux Dot Eg, Ez: 2635 lm
 Light efficiency Dot Dg, Ds, E: 108,7 lm/W
 Light efficiency Dot Eg, Ez: 99 lm/W
 Colour temperature: 4000K
 Color rendering index: Ra ≥80
 Colour tolerance: MacAdam ≤3 SDCM
 Light output ratio (LOR): 100%
 Light distribution up/down: 0/100
 Expected lifespan: L90 >50 000 h
 Expected lifespan: L70 >100 000 h

Connection: The standard on/off electronic HF ballast delivered with 2,5 meters of cable 3x0,75 mm² and Euro plugg. The SwitchDIM/DALI delivered without cable.

Electrical data: 220-240 V, 50-60 Hz, power factor cos φ>0,98. Electronic HF ballast or electronic HF dim ballast for digital regulation. Light source: led module of 27W total.

Electrical approvals: IP20, Class 1.

Visual appearance: Tile surface finish; White Frost, nearest NCS colour sample S 0500-N, 85% light reflectance. Gloss < 1.

Cleanability: Daily dusting and vacuum cleaning. Weekly wet wiping.

Accessibility: The tiles are easily demountable. Minimum demounting depth according to installation diagrams.

Installation: Installed according to system range which include information regarding minimum overall depth of system. The tile with luminaire housing rests on the T-profiles and the SwitchDIM/DALI and standard on/off ballasts are fastened to the grid or tile next to the luminaire with velcro. Once the tile with luminaire and ballast are in place a certified installation electrician must connect the wiring to sockets or to the next luminaire.

Installation diagram in detail www.ecophon.com

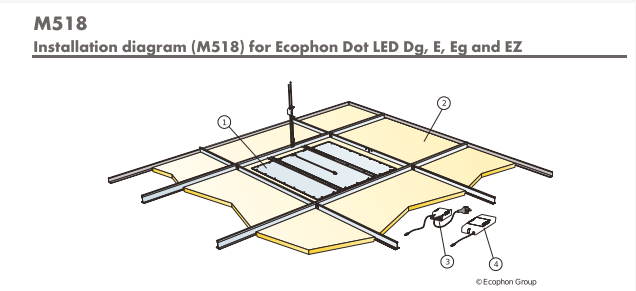
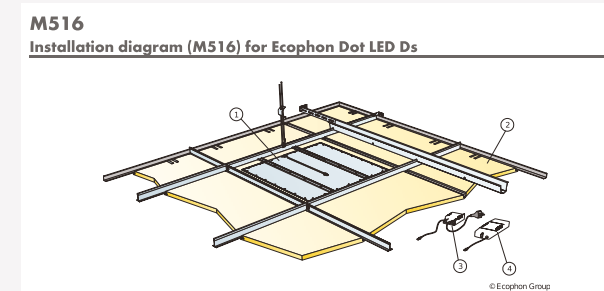

Ecophon is the leading supplier of indoor acoustic solutions that improve working performance and quality of life. We believe in the difference sound can make to our everyday lives, and are passionate advocates for the importance of room acoustics to people's wellbeing – whatever the space, activity or need.

Having a sound effect on people is the principle that guides all we do. We're proud of the Swedish heritage and human approach that promise is founded on. Our uncompromising commitment to transparent sustainable practice. And, as members of the Saint-Gobain Group, to be doing our part in making the world a better home.

